

6 5 4 3 2 1

D

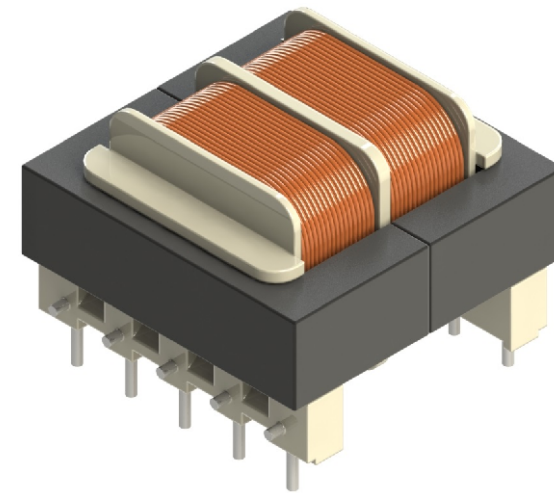
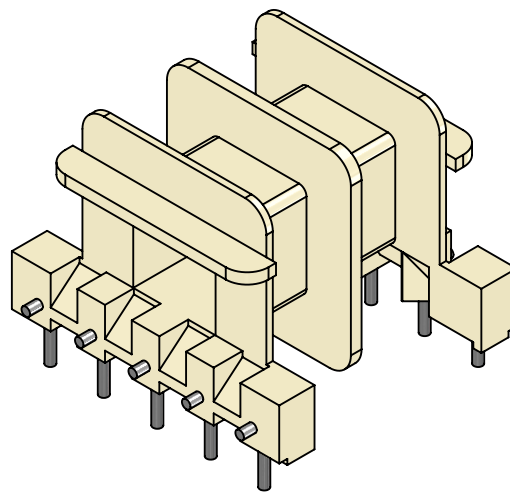
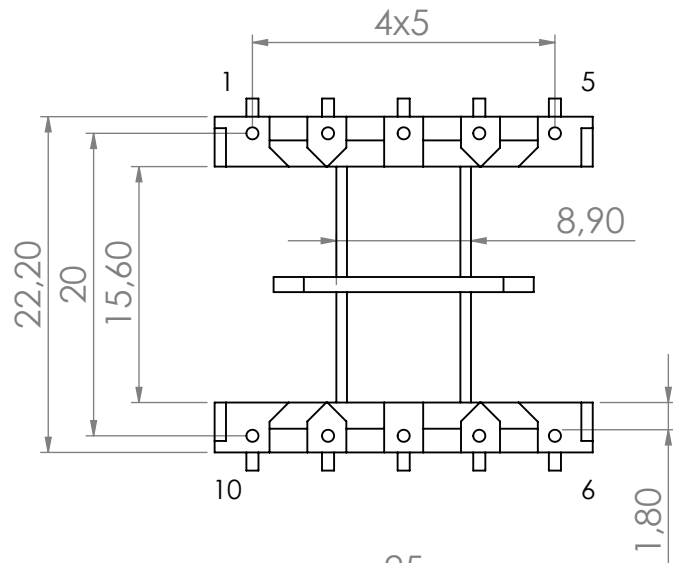

D

C

C

B

B

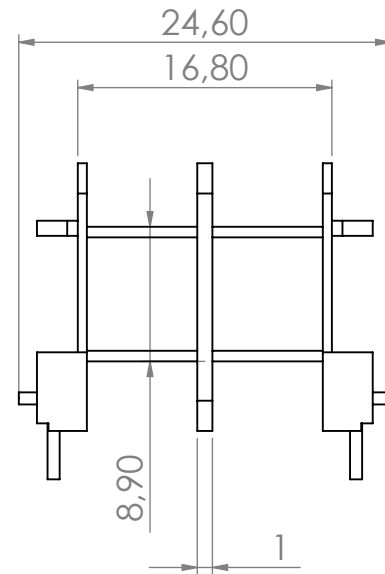
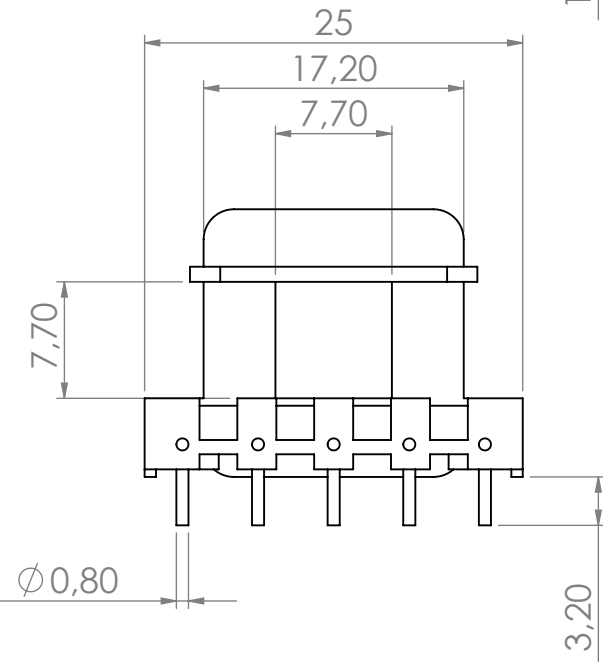

Top view

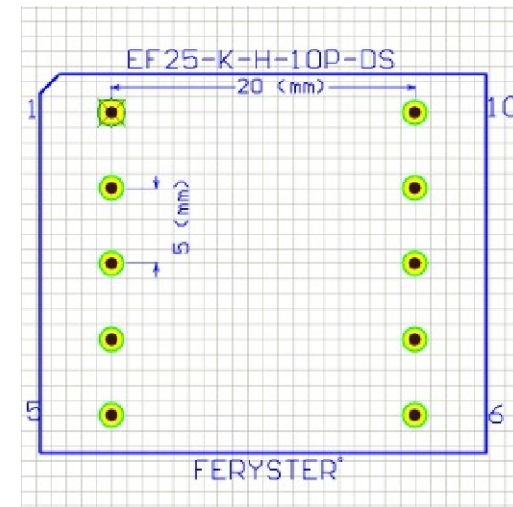

A

A

Bobbin material: PA 6.6 - Durethan AKV 30H [E245249](#)

Pełna dokumentacja techniczna oraz materiały pomocnicze dla projektantów [www.feryster.pl](http://www.feryster.pl)



FERYSTER  
ul. Traugutta 4, 68-120 ŁŁOWA  
info@feryster.pl

NR RYSUNKU

EF25\_7-K-H-10P-DS

A4

SKALA:2:1

ARKUSZ 1 Z 1

6 5 4 3 2 1